

# Boltwood Cloud Sensor III

Make the most of clear skies.



The newly-designed Boltwood Cloud Sensor III is the must-have weather monitoring device for astronomical observatories. Designed to protect your most valuable equipment from weather damage, the Boltwood Cloud Sensor III can sense wind, rain, and more while enabling automatic observation scheduling through your favourite observatory control applications.

Boltwood Cloud Sensor III utilizes Wi-Fi technology for wireless conditions monitoring from up to five computers. It supports both ASCOM Alpaca interfaces and browser-based monitoring, providing compatibility with any operating system. Both network operation and Wi-Fi hotspot modes are available. For Windows users our Clarity III software is also available, providing extra setup and data logging features

## Optional Wired Version

The Boltwood Cloud Sensor III is also available with an optional wired interface version (BOLTWOOD-III-S), which has an RS-232 serial interface and also supports Wi-Fi operation. A 100' (30 m) serial cable is included.

For situations where radio-quiet operation is required, a serial-only version is available (BOLTWOOD-III-SO). This version uses the same hardware but has the Wi-Fi transmitter permanently disabled. A 100' (30 m) serial cable is included.

For serial interface operation, an ASCOM driver is available for operating the sensor under Microsoft Windows. The serial protocol is also documented in the user manual to facilitate custom software solutions. Note that this ASCOM driver is not compatible with Wi-Fi operation, which does not require a driver as it uses a direct Alpaca network connection to the sensor.

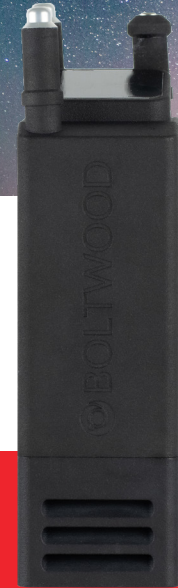

## Powerful Sensor Technology

The primary sensors used for determining safe/unsafe observing conditions are cloud detection, rain detection, wind speed limits, and daylight. The user can also set limits on other parameters, including humidity, temperature, etc.

The Boltwood Cloud Sensor III will trigger a contact closure (relay) output when it detects adverse conditions. When connected to an observatory roof controller such as the MaxDome II system, this will cause the observatory to close. Note that this will not park your telescope or other equipment.

## The Perfect Software

Many users use software to operate the observatory in response to the weather conditions. Diffraction Limited makes Cyanogen Imaging® MaxIm DLTM software, that includes a flexible observatory shutdown capability.

## Connect Anywhere

Boltwood Cloud Sensor III communicates via a WiFi connection. It can operate as a WiFi hotspot or connect directly to your wireless network. It provides browser-based status and configuration screens. It also provides ASCOM Alpaca IObservingConditions and ISafetyMonitor interfaces, enabling direct access to sensor readings by ASCOM-compatible astronomical software packages.

## Powered. Always.

The sensor operates from a 10.5V to 24V DC power source, making it compatible with 12V solar-charged battery systems. A universal AC adapter and extension cable comes standard to connect with available central power locations.

The sensor detects:

- Clouds
- Rain Drops
- Wet snow
- Wind Speed
- Temperature
- Humidity
- Dew Point
- Barometric Pressure
- Daylight
- Input Voltage

**TECHNICAL SPECIFICATIONS**

Model	Boltwood III Wi-Fi	Boltwood III-S Wi-Fi and Serial	Boltwood III-SO Serial Only
DC Input Power	10.5VDC to 24VDC, 1A Maximum		
AC Adapter	100VAC to 250VAC, 50/60 Hz		
Roof Close Contact	Relay switched contact, rated 12V 1A		
Roof Close Circuit Rating	12V, 1A		
Connectivity	Wi-Fi (IEEE802.11b/g/n) Connectivity for multiple clients	WiFi (IEEE802.11b/g/n) and EIA RS-232 Serial port	EIA RS-232 Serial Port
Center Frequency Range	2412 ~ 2484 MHz		
Country Policy	Automatic configuration based on network station		

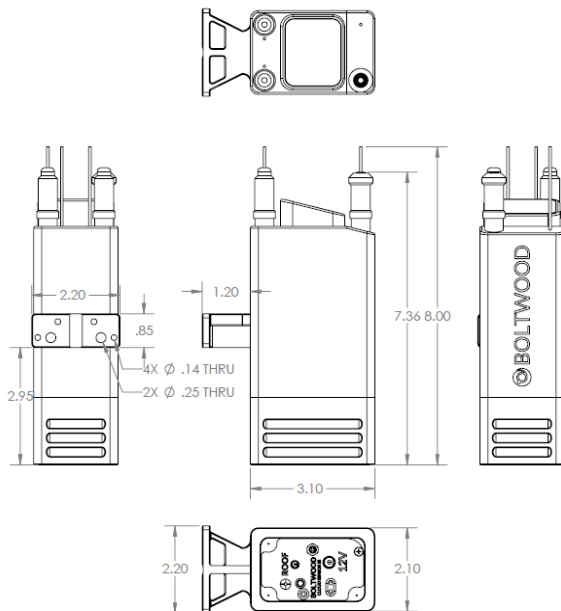

**Quick Mount Adapter**

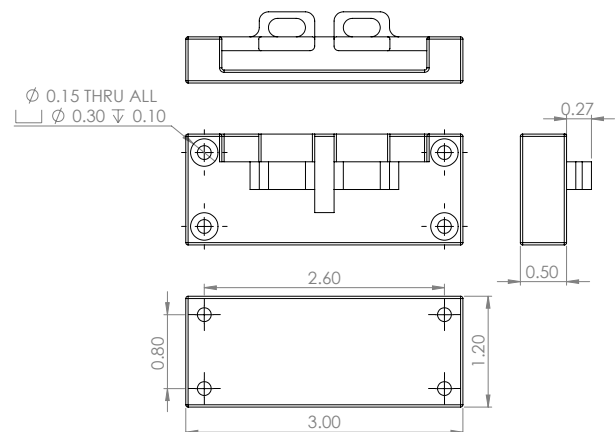

**ORDER THE SBIG SCIENTIFIC CAMERA OF YOUR DREAMS THIS YEAR FROM OUR WORLDWIDE NETWORK OF DEALERS**

SBIG®, ALUMA®, and Cyanogen Imaging® are registered trademarks of Diffraction Limited. StarChaser, ST-4, STXL, STX, MaxIm DL, MaxIm LT are trademarks of Diffraction Limited. All other trademarks, service marks, and trade names are the property of their respective owners.