

### MD30 maintenance

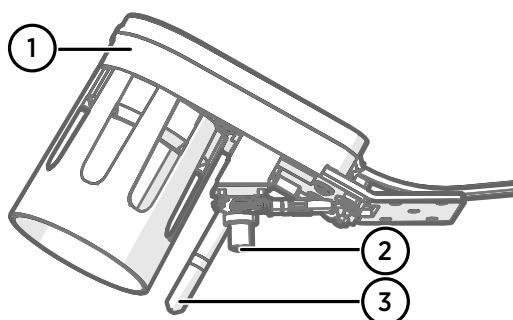

- 1 Surface state sensor
- 2 Surface temperature sensor MT10
- 3 Air temperature and humidity sensor HMP113

Table 1 MD30 maintenance

Task	Frequency
<b>Preventive maintenance</b>	
Check error messages	–
Clean surface state sensor window	As needed
Clean surface temperature sensor	Annually
Replace filter of air temperature and humidity sensor	Annually
Perform 3-step calibration (clean, adjust with plate, drive on dry road)	Annually
<b>Repair maintenance</b>	
Replace air temperature and humidity sensor	As needed
Replace surface temperature sensor	As needed



For MD30 instructions, including documents and videos, see <https://www.vaisala.com/en/support/md30>.



PUBLISHED BY  
Vaisala Oyj  
Vanha Nurmijärventie 21  
FI-01670 Vantaa, Finland  
© Vaisala Oyj 2020

All rights reserved. Any logos and/or product names are trademarks of Vaisala or its individual partners. Any reproduction, transfer, distribution or storage of information contained in this document is strictly prohibited. All specifications – technical included – are subject to change without notice.

# VAISALA

## Cleaning surface state sensor window



- Cloth
- Glass cleaner

Clean the surface state sensor window when sensor gives a window contamination warning.

For cleaning, the mobile sensor can remain mounted on the vehicle. When cleaning, remove possible dirt, ice, and snow.

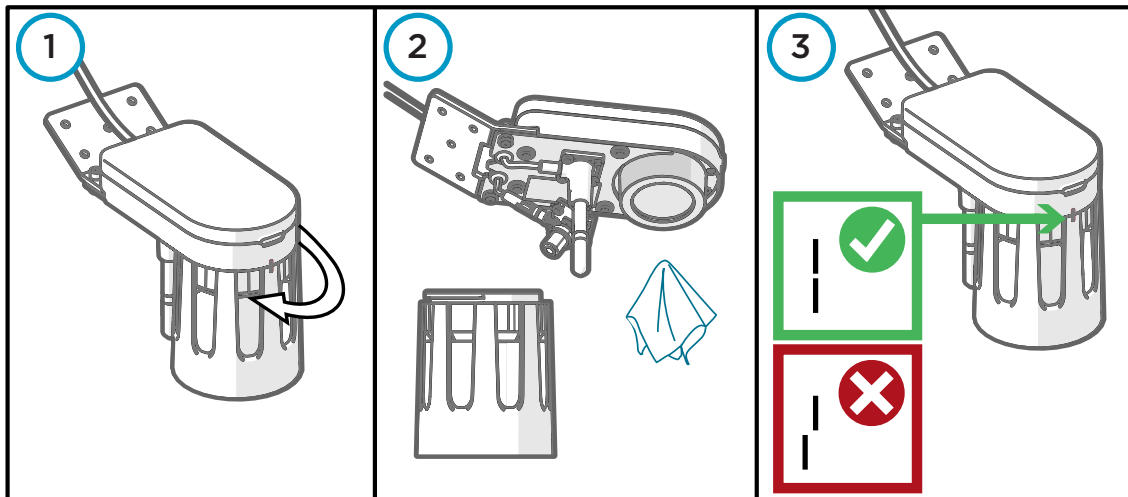

- ▶ 1. Remove the hood by turning it counterclockwise.
2. Apply glass cleaner on the window of the surface state sensor. Clean with a soft, lint-free cloth. Clean also the hood.
3. Attach the hood to the body by turning the hood clockwise. Make sure that the markings in the hood and sensor body are aligned.

## Cleaning surface temperature sensor



- Cotton swab
- Compressed air or air pump
- Glass cleaner

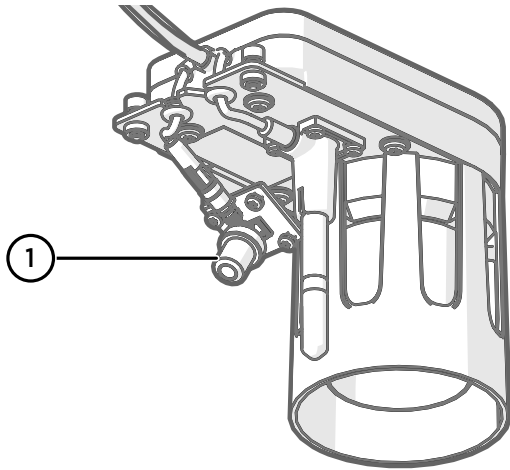

1 Surface temperature sensor

Clean the surface temperature sensor annually, or more often if conditions require it.

- ▶ 1. Remove the surface temperature sensor from the body.
2. Apply glass cleaner on the surface temperature sensor. Insert a cotton swab in the thread and turn it clockwise. Remove the cotton swab by turning it counterclockwise in the thread. If required, use compressed air or an air pump.
3. Attach the surface temperature sensor to the body.

# Replacing filter of air temperature and humidity sensor



- Screwdriver Torx 10

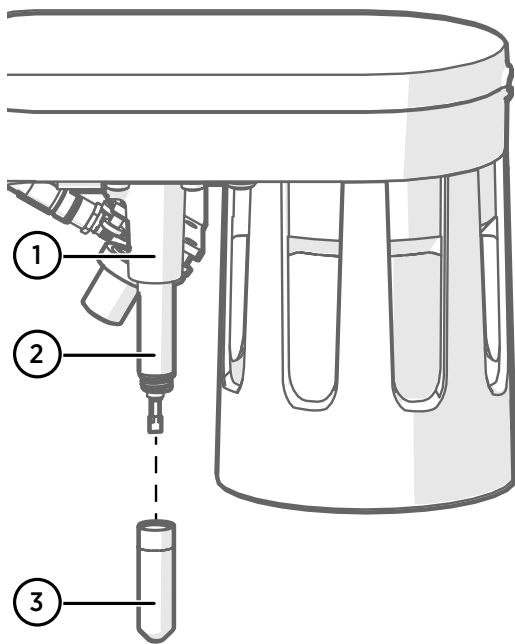

- 1 Air temperature and humidity sensor
- 2 Probe body
- 3 Filter

Replace the filter when it is damaged or dirty.

The replacement filter comes with an O ring, but do not use it.

- ▶ 1. Carefully remove the filter from the probe. Holding the filter by its collar, rotate the filter counter-clockwise, then pull it out.



**CAUTION!** Do not touch the sensor heads.

2. Without delay, install the new filter carefully on the air temperature and humidity sensor. Rotate the filter clockwise, making sure the filter sits straight and meets the threads properly.

# Replacing air temperature and humidity sensor



- Electric joint compound
- Screwdriver Torx 10

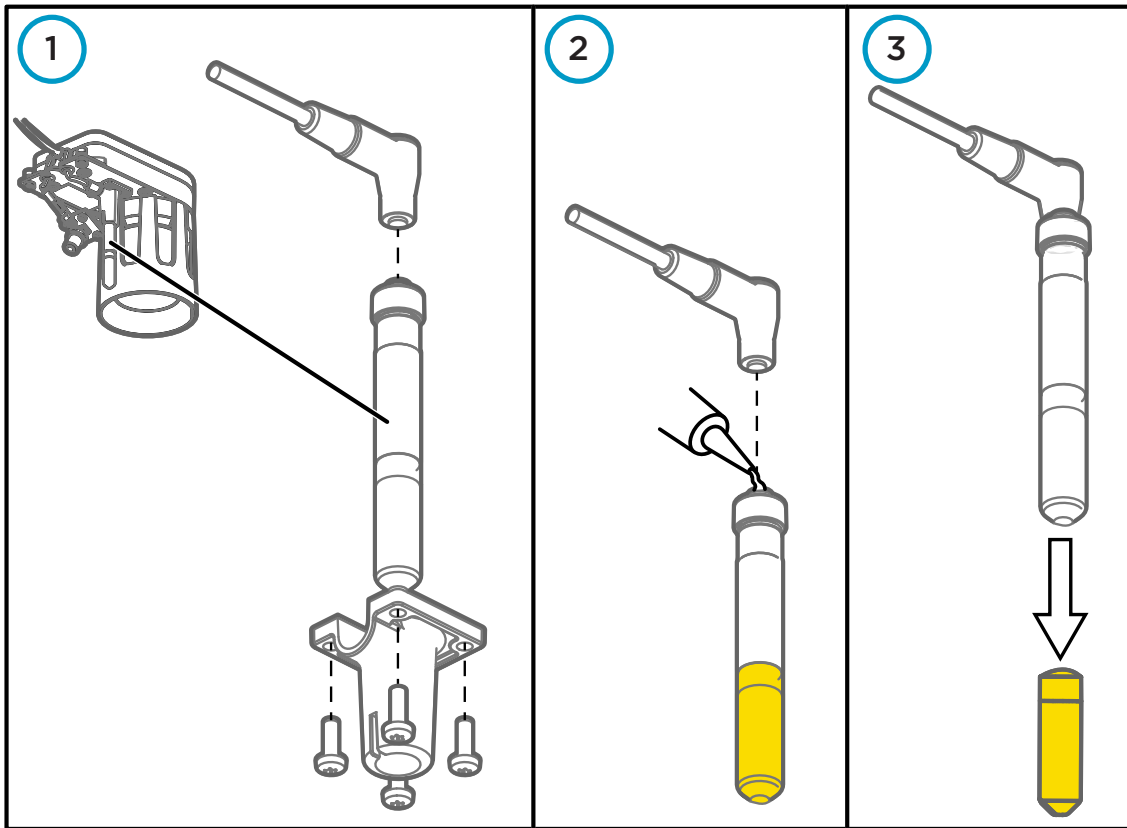

- ▶ 1. Loosen the 4 screws that hold the temperature sensor in place, pull the air temperature and humidity sensor (HMP) through the holder, and disconnect the sensor cable.
2. Add electric joint compound at the end of the connector of the replacement sensor. Connect the sensor cable to the replacement sensor.
3. Remove the yellow cover from the replacement sensor.
4. Push the replacement sensor through the holder and attach the holder with 4 screws.

## Replacing surface temperature sensor



- Screwdriver Torx 10

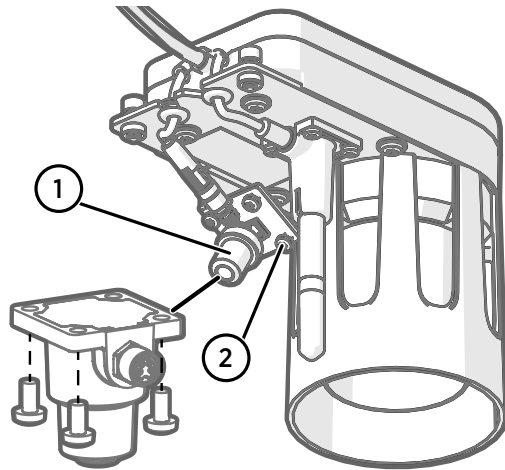

- 1 Surface temperature sensor
- 2 Screw (4 pcs)

- ▶ 1. Loosen the 4 screws that hold the temperature sensor in place, remove the sensor, and disconnect the sensor cable.
2. Connect the sensor cable to the replacement sensor.
3. Attach the replacement sensor with 4 screws.

# MD30 troubleshooting

Table 2 Mobile sensor status LED

LED	Status
Orange	Powered up
Green (steady)	Startup ongoing
Green (blinking)	Operational
Red	System is in error state and cannot be used

Table 3 Troubleshooting

Problem	Probable cause	Actions
<b>Installation and setup</b>		
Phone is not showing data.	Device pairing was not successful or system is not getting power.	Check that car charge adapter and car phone charger are connected and mobile sensor and mobile phone are powered. If pairing is still not successful, repeat pairing.
Installation was verified with reference plate and mobile sensor adapted to road surface types, but mobile sensor gives inaccurate readings.	Road was not completely dry when dry road reference was performed.	Carry out dry road reference again. See <i>Vaisala Mobile Detector MD30 Setup Guide</i> .
	Road surface type in area of operation differs significantly from road surface type in location where dry road reference was performed.	
	Plate was not clean and dry during plate calibration. Plate was not positioned correctly during plate calibration.	Carry out plate reference. See <i>Vaisala Mobile Detector MD30 Setup Guide</i> .
Calibration stops or does not succeed.	There is an active error.	Check <b>Unit status</b> and <b>Error status</b> information in RoadAI, and act on any open errors.
Dry road not available.	–	Type the values manually or use factory settings until local dry road becomes available.
<b>Operation</b>		
System is in error state (mobile sensor LED is red).	Several possible causes.	Restart mobile sensor. If the error persists, see error messages for more information.
Phone is not showing data.	System is not getting power.	Check that car charge adapter and car phone charger are connected and mobile sensor and mobile phone are powered.

Problem	Probable cause	Actions
Phone does not upload data to network.	Phone battery level is < 85 % and phone is not connected to charger.	Connect phone to charger.
	No network connection.	Check Internet connection settings. Check that SIM card is inserted.
		Change location.
Phone SD card is empty.	Data has been uploaded to server.	-

Check the error message for information about the error and follow the relevant instructions.

Table 4 Error messages

Bit <sup>1)</sup>	Message	Probable cause	Actions
0	Surface temperature sensor error	Cables may be loose, damaged, or disconnected.	Check cables and connectors. If the problem persists, replace mobile sensor.
1	Air temperature error		
2	Relative humidity error		
3	Window contamination alarm <sup>2)</sup>	Mobile sensor window is heavily contaminated.	Clean the window.
4	Laser status error	-	Restart mobile sensor.
5	Laser heating error		
6	Excessive ambient light detected	Sunlight is reflected from road surface to mobile sensor.	Move vehicle or reposition mobile sensor.
7	Receiver error	-	Restart mobile sensor.
8	Signal level out of range, gain adjustment limit reached	-	Check installation height and angle of mobile sensor.
9	Received signals contain too much noise	-	Check that mobile sensor is firmly attached to vehicle.
10	Optical measurement data timeout	-	Restart mobile sensor.
11	Low input voltage	Incorrect operating voltage.	Check operating voltage.
12	High input voltage		
13	Flash failure status	-	Restart mobile sensor.
14	Internal temperature too high	Mobile sensor overheated.	Disconnect mobile sensor from power supply.
15	Reference status: 0 = OK 1 = Invalid or not set	-	Verify installation with reference plate and adapt mobile sensor to road surface types.
16	Factory calibration status: 0 = OK 1 = Not calibrated	-	Return mobile sensor to Vaisala.



Bit <sup>1)</sup>	Message	Probable cause	Actions
17-31	Reserved for future use	–	–

1) Bit is shown in MD30 interface response data message, not in RoadAI.

2) Reported by MD30 models that have the window contamination feature.

Table 5 Status information

Bit <sup>1)</sup>	Message	Value	Description
0	Not ready to measure	0 = Ready 1 = Not ready	Unit is starting up. When unit reaches full operational status, the flag is cleared. Measurement data may be invalid. If the condition persists, check error bits.
1	Reference setting ongoing	0 = Not ongoing 1 = Ongoing	If reference setting does not start, check status information bits 10 ... 13 and error bits.
2	Laser temperature change in progress	0 = Not ongoing 1 = Ongoing	Unit operational, but measurement data may be invalid. Wait for laser temperature change to finish. If the condition persists, check error bits.
3	Window contamination warning <sup>2)</sup>	0 = OK 1 = Contaminated	Window is getting contaminated. Clean the window.
4	Window heating	0 = OK 1 = Not working	If heating is not working, monitor window contamination.
5	Low input voltage detected	0 = Voltage OK 1 = Voltage low	Unit operational, but check input voltage.
6	High input voltage detected	0 = Voltage OK 1 = Voltage high	
7	High internal temperature detected	0 = Temperature OK 1 = Temperature high	First notification of unit getting too hot.
8	Temperature unit	0 = °C 1 = °F	–
9	Layer thickness unit	0 = mm 1 = inch	–
10	Reference setting interrupted due to laser temperature change	0 = False 1 = True	Repeat reference setting when laser temperature change has finished.
11	Reference setting interrupted due to hardware error, check parameter 0x56	0 = False 1 = True	Check error bits and parameter 0x56, which contains reason for error.
12	Reference setting values are not updated due to poor signal quality	0 = False 1 = True	Excessive variation in road surface type. Find more representative road surface.

Bit <sup>1)</sup>	Message	Value	Description
13	Reference setting was interrupted by client	0 = False 1 = True	–
14	Signal levels low, uncertainty in surface layer thickness results	0 = False 1 = True	Unit operational, but measurement data may be invalid. Verify installation and clean window.
15 - 31	Reserved for future use	–	–

1) Bit is shown in MD30 interface response data message, not in RoadAI.

2) Reported by MD30 models that have the window contamination feature.

# MD30 spare parts and accessories

Table 6 MD30 spare parts and accessories

Name	Order Code
Hood	MDHOOD
Air temperature and humidity sensor HMP113 for MD30	MD30HMPSP
Filters for air temperature and humidity sensor (5 pcs)	MD30HMPFILTERSET
Surface temperature sensor MT10	MT10SP
Mounting bracket for MD30	MDBRACKET
Sensor-to-power cable 8 m (26 ft)	MDCABLE8
Extension set	MD30EXTSET
Cable for HMP113 or MT10 installation to side of car 3 m (9 ft 10 in)	HMT120Z300
Cable for HMP113 or MT10 installation to side of car 5 m (16 ft 4 in)	HMT120Z500
Cable for HMP113 or MT10 installation to side of car 10 m (32 ft 9 in)	HMT120Z1000
Serial-to-USB cable for laptop connection	240884
Electric joint compound	12475SP
Dry reference plate	MDPLATE
Splitter for car power outlet	260028
Mobile phone USB charger	256824
Mobile phone USB-C charging cable, 3-m (9-ft 8 in)	258180
Mobile phone holder	256791
Mobile phone (SIM not included)	– 1)
Memory card, 128 GB	256826
Polarization filter for phone camera	258143
Bluetooth media button	256825

1) Check model availability from Vaisala Sales.



**WARNING!** Failure to comply with these precautions or with specific warnings elsewhere in these instructions violates safety standards of design, manufacture, and intended use of the product. Vaisala assumes no liability for the customer's failure to comply with these requirements.



**WARNING!** Do not substitute parts or modify the system, or install unsuitable parts in the system. Improper modification can damage the product or lead to malfunction.



**WARNING!** Follow local and state legislation and regulations on occupational safety.

# MD30 maintenance checklist



Fill in the checklist and save it to record completed tasks.  
Make copies of the list as needed.

Table 7 MD30 maintenance checklist

Task	Reference	OK/ Not OK	Remarks
MD30 serial number:			
Maintenance person:			
Date (day/month/year):			
<b>Maintenance preparations</b>			
1	Check error messages	<a href="#">MD30 troubleshooting (page 7)</a>	
		<ul style="list-style-type: none"> <li>RoadAI: scroll right on measurement grid</li> <li>Through interface: use SEND DATA request</li> </ul>	
<b>Annual maintenance</b>			
1	Clean surface temperature sensor	<a href="#">Cleaning surface temperature sensor (page 3)</a>	
2	Replace filter of air temperature and humidity sensor	<a href="#">Replacing filter of air temperature and humidity sensor (page 4)</a>	
3	Perform 3-step calibration	See <i>Vaisala Mobile Detector MD30 Setup Guide</i>	
<b>As needed</b>			
1	Clean surface state sensor window	<a href="#">Cleaning surface state sensor window (page 2)</a>	
2	Replace air temperature and humidity sensor	<a href="#">Replacing air temperature and humidity sensor (page 5)</a>	
3	Replace surface temperature sensor	<a href="#">Replacing surface temperature sensor (page 6)</a>	
<b>Notes for next maintenance check</b>			